



# **EXTREN DWB<sup>®</sup>**

## **DESIGN GUIDE**



get incorporated



# **EXTREN DWB® DESIGN GUIDE**

**8" x 6" EXTREN DWB® Hybrid  
and All-Glass Material Configurations**

**36" x 18" EXTREN DWB® Hybrid  
Material Configuration**

## **EXTREN DWB® DESIGN GUIDE**

**8" x 6" EXTREN DWB® Hybrid and All-Glass Material Configurations**

**36" x 18" EXTREN DWB® Hybrid Material Configuration**

Based on Independent Research, Testing and Analysis Under the Direction of:

Professor John J. Lesko, Ph.D.

Department of Engineering Science & Mechanics  
Virginia Polytechnic Institute and State University

&

Professor Thomas E. Cousins, Ph.D.

Via Department of Civil and Environmental Engineering  
Virginia Polytechnic Institute and State University

©Copyright 2003 by Strongwell Corporation  
Bristol, VA, U.S.A.  
All Rights Reserved

---

**TABLE OF CONTENTS**

---

Introduction from Strongwell.....6

Independent Testing Certification .....7

Manufacturing Process.....8

Nomenclature .....9

Physical and Section Properties..... 10

Materials..... 12

Statement of Approach..... 13

Beam Load Tables ..... 15

Web Buckling .....34

Connections.....35

Appendix - Existing Bridge Projects .....44

---

## INTRODUCTION FROM STRONGWELL

---

Strongwell's EXTREN DWB® (Double Web Beam) was developed with the assistance of the U.S. Department of Commerce's Advanced Technology Program (ATP). This involved a three year cooperative research and development program between Strongwell and the Advanced Technology Program.

The goal of Strongwell's ATP project was to design, develop and produce an optimized fiber reinforced polymer (FRP) structural shape for use in heavy structures such as vehicular bridges and offshore drilling platforms. The program included the development of manufacturing processes and equipment to produce this product. The result of Strongwell's efforts is a double web beam with carbon fibers in the top and bottom flanges for increased stiffness.

The carbon/glass "hybrid" (hybrid refers to the combination of carbon and glass reinforcements) beam has a modulus of elasticity of nominally  $6.0 \times 10^6$  psi. The modulus of elasticity of a standard EXTREN® WF beam is  $2.6 - 2.8 \times 10^6$  psi. Additionally, the double web shape has significantly improved the lateral torsional stability of the beam. This increased stability is very significant and reduces the beam's need for lateral bracing.

Strongwell presently produces two different sizes, an 8" x 6" EXTREN DWB® (8" DWB) and a 36" x 18" EXTREN DWB® (36" DWB). Both of these sizes have undergone extensive laboratory testing. The 8" DWB was installed on a short span bridge in Blacksburg, Virginia, in June 1997.<sup>1</sup> The 36" DWB was installed in a 38-foot clear span bridge on Route 601 over Dickey Creek in Sugar Grove, Virginia in September 2001.<sup>2</sup>

The EXTREN DWB® design data presented herein are the result of extensive testing and evaluation work by two engineering departments of Virginia Tech - the Via Department of Civil & Environmental Engineering and the Department of Engineering Sciences and Mechanics. The availability of Virginia Tech's heavy structures laboratory and the recognized expertise of its engineering professors provided Strongwell with an independent third party evaluation of the EXTREN DWB®.

Strongwell's mechanical testing laboratory has also created a database of coupon test properties for the EXTREN DWB® structural shape. This database enables Strongwell to compare the coupon properties of each manufactured lot of EXTREN DWB® shapes and to certify that each lot meets the performance characteristics and criteria identified in this design guide. Strongwell's certification of these properties provides structural engineers with the confidence that EXTREN DWB® structural shapes meet the performance requirements listed herein.

This guide includes design information for the 8" x 6" and 36" x 18" shapes. The enclosed information allows structural engineers to design their projects with EXTREN DWB® beams with confidence.

Strongwell received raw material support in manufacturing the 36" DWB from Dow Chemical, Owens Corning and Fortifil Fibers. Their assistance in manufacturing the beams used for performing the various destructive testing is very much appreciated.

<sup>1</sup> Hayes, M.D., Lesko, J.J., Haramis, J., Cousins, T.E., Gomez, J., Massarelli, P., "Laboratory and Field Testing of Composite Bridge Superstructure," ASCE, Journal of Composites for Construction, Vol. 4, No. 3, 2000, pp. 120-128.

<sup>2</sup> Hayes, M.D., Lesko, J.J., Cousins T., Waldron C., Witcher D., Barefoot G., & Gomez J., "Design of a Short Span Bridge Using FRP Girders," Composites in Construction International Conference, October 10-12, 2001, Porto, Portugal.

---

**INDEPENDENT TESTING CERTIFICATION**

---



College of Engineering  
Blacksburg, Virginia 24061

**MEMORANDUM**

**To:** Users of the EXTREN DWB® Design Guide

**FROM:** JOHN J. LESKO, PHD.  
DEPARTMENT OF ENGINEERING SCIENCE & MECHANICS

THOMAS E. COUSINS, PHD.  
VIA DEPARTMENT OF CIVIL AND ENVIRONMENTAL ENGINEERING

**Subj:** The development of the EXTREN DWB® Design Guide

**Date:** 10 February 2003

The basis for this design manual comes from independent stiffness and strength characterizations carried out in our laboratories. These tests were completed on 8" x 6" all-glass and hybrid DWB and the 36" x 18" hybrid DWB manufactured under production conditions and supplied to us by Strongwell Corp. The final design values presented in the EXTREN DWB® Design Guide are the direct result of these tests and interpretations described within the guidelines.

### WHAT IS A FIBER REINFORCED POLYMER COMPOSITE?

Fiber reinforced polymer (FRP) composites consist of a polymer resin matrix reinforced by glass or carbon fibers. The strength and stiffness of a composite component are determined primarily by the type, orientation, quantity and location of the fibers within the part.

In the case of the DWB, engineered fabrics are used in addition to the continuous strand mat and roving employed in standard EXTREN® shapes (typically, stitching layers of roving into desired orientations produces these engineered fabrics). The resulting fabrics offer the advantage of specific placement of particular fiber orientations. Control of off-axis fiber placement and orientation enable designs of structural shapes that are optimized for desired structural characteristics. The resin binds the reinforcing fiber (glass or carbon) together and this resin/glass bond aids in developing stiffness in the part.

The type of resin used influences moisture stability, corrosion resistance, flame retardance, and maximum operating temperature of the composite. The resin also contributes significantly to certain failure characteristics including toughness and fatigue resistance.

### WHAT IS PULTRUSION?

Pultrusion is a manufacturing process for producing continuous lengths of FRP structural shapes. Raw materials include a liquid resin mixture (containing resin, fillers and specialized additives) and reinforcing fibers. The process involves pulling these raw materials (rather than pushing, as is the case in extrusion) through a heated steel forming die using a continuous pulling device. The reinforcement materials are in continuous forms such as rolls of fiberglass mat or doffs of fiberglass roving. As the reinforcements are saturated with the resin mixture (“wet-out”) in the resin bath and pulled through the die, the gelation (or hardening) of the resin is initiated by the heat from the die and a rigid, cured profile is formed that corresponds to the shape of the die.

While pultrusion machine design varies with part geometry, the basic pultrusion process concept is described in the following schematic, Figure 1.

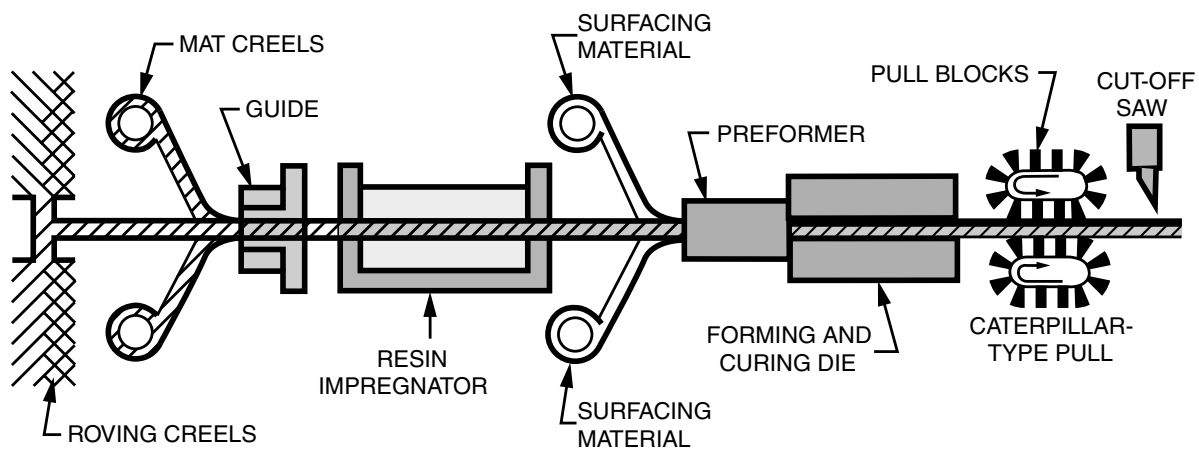

**Figure 1.** Continuous Pultrusion

The creels (mat and roving) position the reinforcements for subsequent feeding into the guides. The reinforcements must be located properly within the composite and are controlled by the reinforcement guides.



---

**MANUFACTURING PROCESS**

---

The resin impregnator saturates (wets out) the reinforcements with a solution containing the resin, fillers, pigment, and catalyst plus any other additives required. The interior of the resin impregnator is carefully designed to optimize the wet-out of the reinforcements.

On exiting the resin bath, the reinforcements are organized and positioned for the eventual placement within the cross-section form by the preformer. The preformer is an array of tooling that squeezes away excess resin as the product is moving forward and gently shapes the materials prior to entering the die. In the die, the thermosetting reaction is heat activated (energy is primarily supplied electrically) and the composite is cured (hardened).

On exiting the die, the cured profile is pulled to the saw for cutting to length. It is necessary to cool the part before it is gripped by the pull block (made of durable urethane foam) to prevent cracking and/or deformation by the pull blocks. Strongwell uses two distinct pulling systems, one that is a caterpillar counter-rotating type and the other a hand-over-hand reciprocating type.

---

**NOMENCLATURE FOR EXTREN DWB®**

---

|                         |   |
|-------------------------|---|
| $A$                     | Cross-sectional area of beam (in)                                     |
| $A_{2 \text{ webs}}$    | Cross-sectional area of both webs — including stiffeners (in)         |
| $A_{2 \text{ flanges}}$ | Cross-sectional area of both flanges (in)                             |
| $A_v$                   | Cross-sectional shear area of beam                                    |
| $c$                     | Distance from outer fiber of the section to the centroid of beam (in) |
| $E_{zz}$                | Flexural Modulus along Z-Z axis (psi)                                 |
| $F_{PCr}$               | Critical bearing stress (psi)   |
| $F_U$                   | Ultimate compressive web bearing stress (psi)                         |
| $G_{zy}$                | Shear Modulus of beam (psi)   |
| $I_{xx}, I_{yy}$        | Moment of Inertia about X-X or Y-Y axis (in <sup>4</sup> )            |
| $J_{\text{eff}}$        | Torsional constant (in <sup>4</sup> )                                 |
| $k$                     | Shear correction factor   |
| $M$                     | Bending Moment (kip-ft)   |
| $L$                     | Length of beam between supports (in or ft), represented as clear span |
| $P$                     | Point load (lb or kip)  |
| $r_{xx}, r_{yy}$        | Radius of Gyration about X-X or Y-Y axis (in)                         |
| $S_{xx}, S_{yy}$        | Section Modulus about X-X or Y-Y axis (in <sup>3</sup> )              |
| $T$                     | Torque (kip•ft, lb•in)  |
| $t_w$                   | Web thickness (in)  |
| $V$                     | Shear (kip)   |
| $\delta$                | Deflection (in)   |
| $\epsilon$              | Strain (in/in)  |
| $\phi$                  | Torsional angle of section rotation (radians)                         |
| $\omega$                | Distributed applied load (lb/ft)                                      |

## PHYSICAL AND SECTION PROPERTIES

Dimensions specified are nominal and apply for both the all-glass and hybrid forms of this beam (shown in Figure 2 and Figure 3). Standard tolerances for the as-pultruded shape (section dimensions and straightness) are also listed in Table 1:

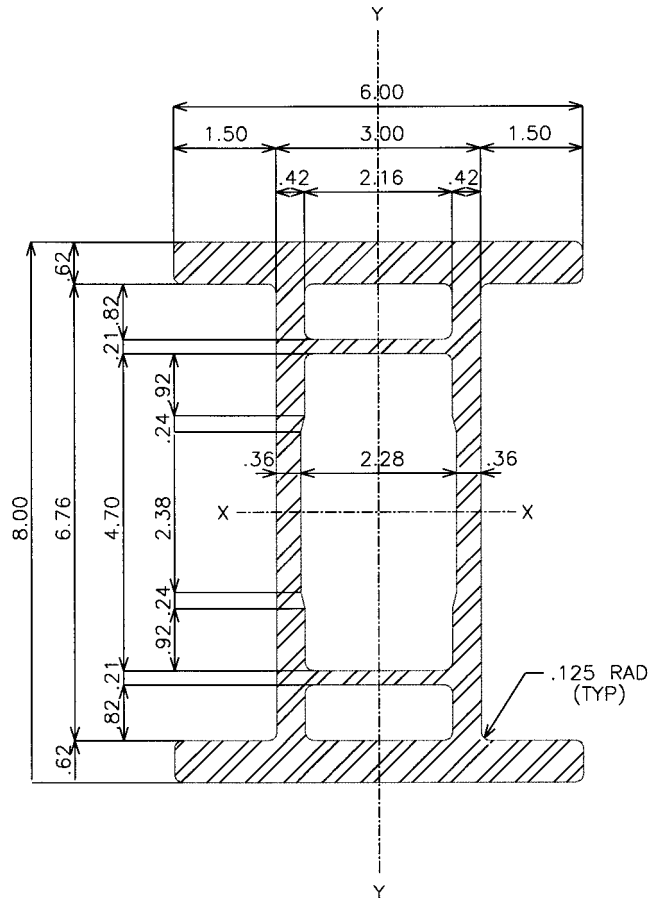

### NOMINAL SECTION PROPERTIES

$$I_{xx} = 129 \text{ in}^4$$

$$S_{xx} = 32.2 \text{ in}^3$$

$$r_{xx} = 3.07 \text{ in}$$

$$A = 13.7 \text{ in}^2$$

$$A_{2 \text{ webs}} = 5.36 \text{ in}^2$$

$$A_{2 \text{ flanges}} = 7.44 \text{ in}^2$$

$$I_{yy} = 31.8 \text{ in}^4$$

$$S_{yy} = 10.6 \text{ in}^3$$

$$r_{yy} = 1.52 \text{ in}$$

$$\text{Weight} = 11.2 \text{ lbs/ft}$$

**Figure 2.** Nominal Section Properties and Dimensions (in inches) for the 8" DWB

**PHYSICAL AND SECTION PROPERTIES**

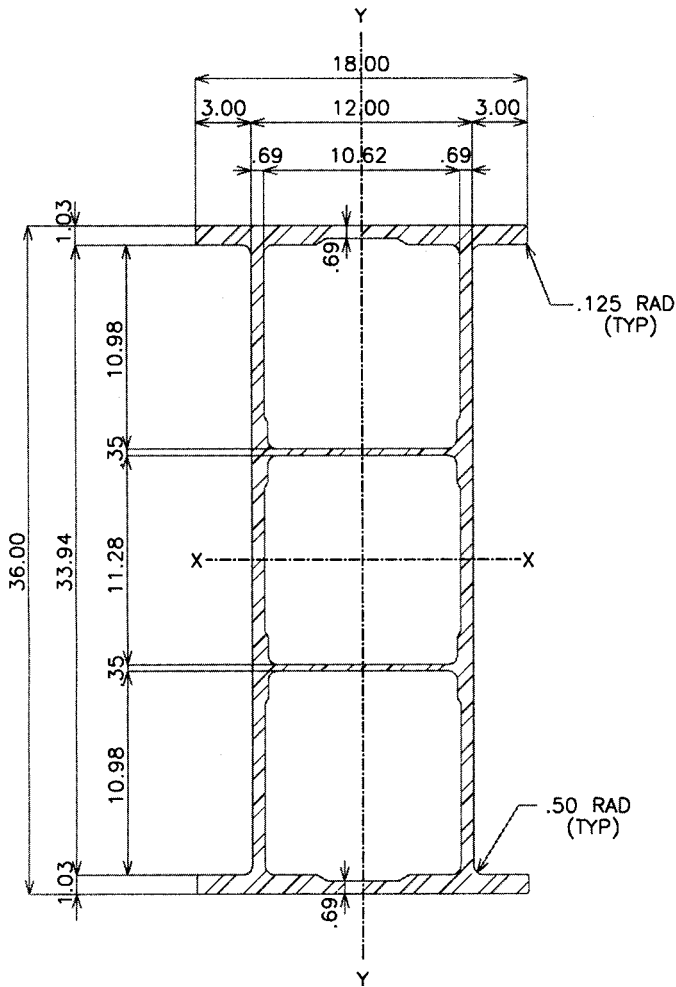

**NOMINAL SECTION PROPERTIES**

- $I_{xx} = 15291 \text{ in}^4$
- $S_{xx} = 849 \text{ in}^3$
- $r_{xx} = 12.9 \text{ in}$
- $A = 91.2 \text{ in}^2$
- $A_{2 \text{ webs}} = 50.1 \text{ in}^2$
- $A_{2 \text{ flanges}} = 34.0 \text{ in}^2$
- $I_{yy} = 2626 \text{ in}^4$
- $S_{yy} = 292 \text{ in}^3$
- $r_{yy} = 5.37 \text{ in}$
- Weight = 70 lbs/lf

**Figure 3.** Nominal Section Properties and Dimensions (in inches) for the 36" DWB

**TABLE 1**  
**STANDARD TOLERANCES**

| <b>Condition</b>      | <b>Tolerance</b>                               |
|-----------------------|--|
| Wall Thickness        | $\pm 15\%$                                     |
| Outside Dimension     | $\pm 1.5\%$                                    |
| Straightness          | .060" x length in ft.                          |
| Flatness              | .040" per inch of outside dimension            |
| Twist                 | $1/2^\circ$ x length in ft., $5^\circ$ maximum |
| Cut Lengths           | -0", +3.00"                                    |
| Squareness of end cut | $\pm 1^\circ$                                  |

### **8" x 6" EXTREN DWB® — ALL-GLASS**

The 8" x 6" EXTREN DWB® - G (8" DWB-G), all-glass beam, is a pultruded structural shape composed of four different types of E-glass reinforcements in a vinyl ester resin matrix. The all-glass laminate includes 0° longitudinal rovings, continuous strand mat, 0°/90° stitched fabric, and ±45° stitched fabric. The approximate fiber volume fraction is 55%. The DWB shape improves the apparent (or effective) modulus of elasticity and the stability of the structure under load versus traditional FRP WF or I shapes. The shape weighs 11.2 pounds per linear foot (11.2/lf).

### **8" x 6" EXTREN DWB® — HYBRID BEAM**

The 8"x 6" EXTREN DWB® - H (8" DWB-H), hybrid beam, is a pultruded structural shape comprised of carbon fiber tows and four different types of glass reinforcements in a vinyl ester resin matrix. The 0° carbon tows replace some of the 0° glass rovings in the top and bottom flanges of the shape. The remainder of the laminate is identical to the all-glass beam. The carbon tows improve the apparent (or effective) modulus of elasticity at least 30% versus the all-glass beam. The approximate fiber volume is 55% (including glass and carbon). The shape weighs 11.2 pounds per linear foot (11.2/lf).

### **36" x 18" EXTREN DWB® BEAM — HYBRID BEAM**

The 36" x 18" EXTREN DWB® (36" DWB-H) is only produced as a hybrid beam. It is a pultruded structural shape composed of carbon fiber tows in the top and bottom flanges and the same four types of E-glass reinforcements as the 8" DWB-G and 8" DWB-H in a vinyl ester resin matrix throughout the entire structural shape. The carbon tows improve the apparent (effective) modulus of elasticity. The approximate fiber volume is 55% (including glass and carbon) and the shape weighs 70 pounds per linear foot (70 lbs/lf). The 36" DWB-H was designed specifically for use in vehicular bridges.

### **ANTICIPATED APPLICATIONS FOR EXTREN DWB®**

This guide is intended for assistance in the design of structures such as bridges, buildings, offshore structures, and miscellaneous heavy structural fabrications.

- Bridges — Primary and secondary stringers and floor beams
- Buildings — Primary and secondary structural members for building components including floor beams, roof beams, purlins, etc.
- Offshore Structures — Floor beams, deck beams, and primary decking structure
- Miscellaneous Structures — Towers, heavy industrial platform and floor beams, pipe racks, etc.

---

**STATEMENT OF APPROACH**

---

The design guide for the Strongwell DWB is presented as a material specification where the material system and its manufacturing process are well defined and controlled. Given these tolerances on the FRP product, guidelines for its use in a structure are defined.

As a guide, the Load Resistance Factor Design (LRFD) approach is used to define these operating limits.<sup>3</sup> In this approach, the probability distribution of load/stress (Loads) is compared to the probability of failure strength of the material (Resistance), as illustrated in Figure 4. Selecting the form and size of the structure determines the desired overlap of the two distributions, thus defining the stated allowable risk.

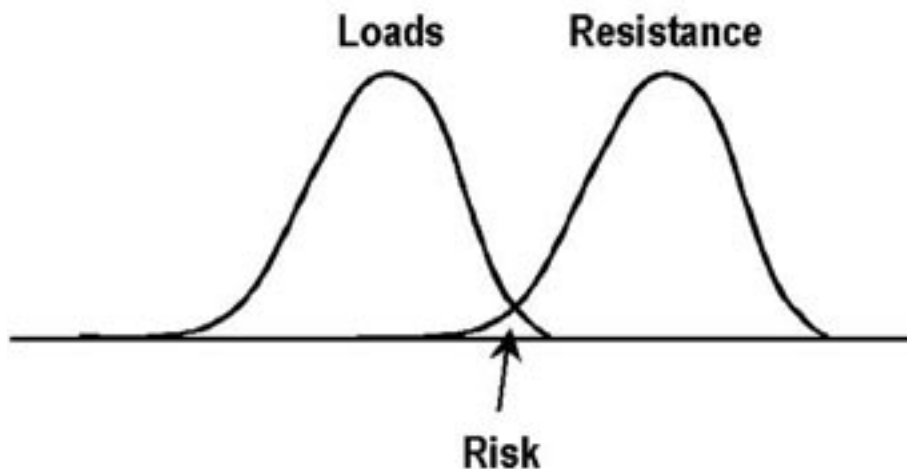

**Figure 4.** LRFD Conceptual Representation for Design

For the purposes of this design guide, we, however, only define for the engineer the Resistance side of the problem. Therefore, the engineer of record is required to define the Loads side of the particular design application based on the variability of loads and operating environment. These details will define the level of reliability required for the application.

In determining the Resistance element of the design problem, based on this material specification, Weibull statistics are employed to describe the variability of the material. The Weibull statistical distribution is widely accepted in the composites community for describing the variability of failure for these material systems.<sup>4,5</sup>

<sup>3</sup> AASHTO, "LRFD Bridge Design Specification," 2nd Edition, American Association of State Highway and Transportation Officials, Washington, D.C., 1998.

<sup>4</sup> Weibull, Waloddi, "A Statistical Distribution Function of Wide Applicability," J. of Applied Mechanics, 1951, pp. 293-297.

<sup>5</sup> Weibull, Waloddi, "A Statistical Representation of Fatigue Failures in Solids, Transactions of the Royal Institute of Technology," No. 27, Stockholm, 1949.

## STATEMENT OF APPROACH

A reliability based approach is used to define A- and B-basis allowable levels of resistance (described further in the Commentary, page 21). These values define for the engineer the level of risk allowed in operating the structure based on a determined design load. Figure 5 illustrates the margin between a design load (supplied by the engineer) and the A-basis or the B-basis resistance listed in this guide. This margin is identified as the level of risk, or inversely, the margin of safety for the design.

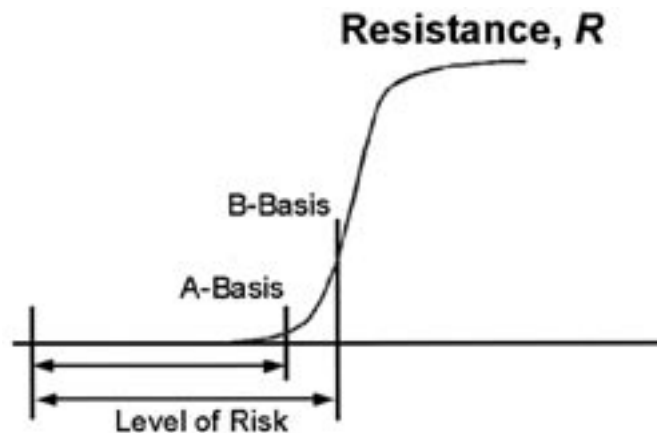

**Figure 5.** Margin of Safety (based on the selection of working loads/stress relative to the A- and B-basis allowables).

This margin or factor of safety should take into account the variability in loads as defined by the engineer for the particular structure. An extensive presentation of load factors is available from the American Society of Civil Engineers.<sup>6</sup> In addition, as the A- and B-basis allowables (resistance) can change over time due to environmental exposure and fatigue. The selected margin of safety must also consider the potential effects of the service environment on the performance of the structure. As FRP structural shapes are new to the industry, definitive criteria for reasonable factors of safety based on durability are not presently available. However, the engineer is referred to several sources for guidance in selecting reduction factors for the stated A- and B-basis allowables.<sup>7</sup> The engineer is also referred to several sources of ongoing research on the durability of the DWB in service and laboratory testing which are not as yet in the form of criteria for the selection of reduction factors.<sup>8</sup> <sup>9</sup> While this guide does not provide load reduction factors, the referenced documents and codes do refer the engineer to appropriate load factors.

<sup>6</sup> Minimum Design Loads for Buildings and Other Structures, ASCE 7-02, American Society of Civil Engineers, Reston, VA, 2002.

<sup>7</sup> EUROCOMP Design Code and Handbook, "Structural Design of Polymer Composites," Ed Clarke, J.L., E&F Spon, London, UK, 1997, pp. 37-41.

<sup>8</sup> Neely, W. D., "Evaluation of the In-Service Performance of the Tom's Creek Bridge," M.S. Thesis Via Department of Civil & Environmental Engineering, Virginia Tech, May 2000, electronic thesis available on-line at: <http://scholar.lib.vt.edu/theses/index.html>.

<sup>9</sup> Senne, J.L., "Fatigue Life of Hybrid FRP Composite Beams," M.S. Thesis, Department of Engineering Science & Mechanics, Virginia Tech, July 2000, electronic thesis available at <http://scholar.lib.vt.edu/theses/index.html>.

**BEAM LOAD TABLES**

The following load tables have been developed using the Load Resistance Factor Design (LRFD) approach and are further defined later in this section.

**TABLE 2**  
**8" x 6" EXTREN DWB® - G (All-Glass)**

Major Axis **A-Basis** Properties

$$E_{zz} = 4.01 \times 10^6 \text{ psi} \quad kG_{zy} A_v = 1.0 \times 10^6 \text{ psi-in}^2 \quad M_{\max} = 96.1 \text{ kip ft.}$$

**A-Basis** Allowable Distributed Loads in Pounds Per Lineal Foot

| Span<br>in Ft. | Capacity<br>Moment | Deflection |       |       |       |       |       |       |       |
|----------------|--------------------|------------|-------|-------|-------|-------|-------|-------|-------|
|                |                    | L/180      | L/240 | L/300 | L/360 | L/420 | L/500 | L/600 | L/800 |
| 8              | 12013              | 1945       | 1459  | 1167  | 973   | 834   | 700   | 584   | 438   |
| 10             | 7688               | 1140       | 855   | 684   | 570   | 488   | 410   | 342   | 256   |
| 12             | 5339               | 716        | 537   | 429   | 358   | 307   | 258   | 215   | 161   |
| 14             | 3922               | 475        | 356   | 285   | 237   | 204   | 171   | 142   | 107   |
| 16             | 3003               | 330        | 247   | 198   | 165   | 141   | 119   | 99    | 74    |
| 18             | 2373               | 238        | 178   | 143   | 119   | 102   | 86    | 71    | 53    |
| 20             | 1922               | 176        | 132   | 106   | 88    | 76    | 63    | 53    | 40    |

**TABLE 3**  
**8" x 6" EXTREN DWB® - G (All-Glass)**

Major Axis **B-Basis** Properties

$$E_{zz} = 4.25 \times 10^6 \text{ psi} \quad kG_{zy} A_v = 1.6 \times 10^6 \text{ psi-in}^2 \quad M_{\max} = 108 \text{ kip ft.}$$

**B-Basis** Allowable Distributed Loads in Pounds Per Lineal Foot

| Span<br>in Ft. | Capacity<br>Moment | Deflection |       |       |       |       |       |       |       |
|----------------|--------------------|------------|-------|-------|-------|-------|-------|-------|-------|
|                |                    | L/180      | L/240 | L/300 | L/360 | L/420 | L/500 | L/600 | L/800 |
| 8              | 13463              | 2338       | 1754  | 1403  | 1169  | 1002  | 842   | 701   | 526   |
| 10             | 8616               | 1322       | 992   | 793   | 661   | 567   | 476   | 397   | 298   |
| 12             | 5983               | 811        | 609   | 487   | 406   | 348   | 292   | 243   | 183   |
| 14             | 4396               | 530        | 398   | 318   | 265   | 227   | 191   | 159   | 119   |
| 16             | 3366               | 364        | 273   | 218   | 182   | 156   | 131   | 109   | 82    |
| 18             | 2659               | 260        | 195   | 156   | 130   | 112   | 94    | 78    | 59    |
| 20             | 2154               | 192        | 144   | 115   | 96    | 82    | 69    | 58    | 43    |

**Failure Mode:** The controlling failure mode observed for the all-glass beams was delamination within the compression flange. The tension flange typically was left intact and able to support load. In some cases, interply damage was observed in the tension flange and less able to carry bending loads.

**Lateral Torsional Stability:** Flexural stiffness and strength characterizations were carried out with no lateral supports for spans to 20'. Thus, for spans to 20', flexural strength is the controlling limit state for both all-glass and hybrid beams. In subsequent flexural tests on laterally unsupported all-glass spans of 20' to 40', lateral-torsional buckling was not observed at deflections to L/90.

## BEAM LOAD TABLES

**Long-term Performance, Fatigue & Durability:** Presently there is limited information regarding the long-term performance of the beam in combined hygro-thermal mechanical service environments. Fatigue loading of the hybrid beam has revealed no loss in stiffness and no failure after 10 million cycles at an applied moment of 37.3 kip ft.,<sup>9</sup> slightly above the A-basis allowable single cycle moment capacity of 36.1 kip ft. Further field work with the beams in the Tom's Creek Bridge, Blacksburg, VA, has demonstrated that the beam can withstand 15 months in service with no loss in stiffness and strength under a modest service environment.<sup>8</sup> Moreover, no residual creep deflection was observed following the 15 months in service.<sup>8</sup>

**TABLE 4**

**8" x 6" EXTREN DWB® - H (Hybrid)**

**Major Axis A-Basis Properties**

$$E_{zz} = 5.66 \times 10^6 \text{ psi} \quad kG_{zy}A_v = 1.8 \times 10^6 \text{ psi-in}^2 \quad M_{\max} = 36.1 \text{ kip ft.}$$

**A-Basis Allowable Distributed Loads in Pounds Per Lineal Foot**

| Span in Ft. | Capacity Moment | Deflection |       |       |       |       |       |       |       |
|-------------|-----------------|------------|-------|-------|-------|-------|-------|-------|-------|
|             |                 | L/180      | L/240 | L/300 | L/360 | L/420 | L/500 | L/600 | L/800 |
| 8           | 4513            | 2970       | 2228  | 1782  | 1485  | 1273  | 1069  | 891   | 668   |
| 10          | 2888            | 1703       | 1277  | 1022  | 851   | 730   | 613   | 511   | 383   |
| 12          | 2006            | 1054       | 791   | 632   | 527   | 454   | 379   | 316   | 237   |
| 14          | 1473            | 693        | 520   | 416   | 346   | 297   | 249   | 208   | 156   |
| 16          | 1128            | 478        | 358   | 287   | 239   | 205   | 172   | 143   | 107   |
| 18          | 891             | 342        | 257   | 205   | 171   | 147   | 123   | 103   | 77    |
| 20          | 722             | 253        | 190   | 152   | 127   | 109   | 91    | 76    | 57    |

**TABLE 5**

**8" x 6" EXTREN DWB® - H (Hybrid)**

**Major Axis B-Basis Properties**

$$E_{zz} = 5.97 \times 10^6 \text{ psi} \quad kG_{zy}A_v = 2.2 \times 10^6 \text{ psi-in}^2 \quad M_{\max} = 51.6 \text{ kip ft.}$$

**B-Basis Allowable Distributed Loads in Pounds Per Lineal Foot**

| Span in Ft. | Capacity Moment | Deflection |       |       |       |       |       |       |       |
|-------------|-----------------|------------|-------|-------|-------|-------|-------|-------|-------|
|             |                 | L/180      | L/240 | L/300 | L/360 | L/420 | L/500 | L/600 | L/800 |
| 8           | 6450            | 3266       | 2449  | 1960  | 1633  | 1400  | 1176  | 980   | 735   |
| 10          | 4128            | 1850       | 1388  | 1110  | 925   | 793   | 666   | 555   | 416   |
| 12          | 2867            | 1136       | 852   | 682   | 568   | 487   | 409   | 341   | 256   |
| 14          | 2106            | 743        | 557   | 446   | 372   | 318   | 268   | 223   | 167   |
| 16          | 1613            | 511        | 383   | 306   | 255   | 219   | 184   | 153   | 115   |
| 18          | 1274            | 365        | 274   | 219   | 182   | 156   | 131   | 109   | 82    |
| 20          | 1032            | 270        | 202   | 162   | 135   | 116   | 97    | 81    | 61    |

**Failure Mode:** The controlling failure mode observed for the hybrid beam was delamination within the compression flange, leaving the tensile flange essentially undamaged.

**Lateral Torsional Stability:** Flexural stiffness and strength characterizations were carried out with no lateral supports for spans to 20'. Thus, for spans to 20', flexural strength is the controlling limit state for both all-glass and hybrid beams. In subsequent flexural tests on laterally unsupported hybrid spans of 20' to 40', lateral-torsional buckling was not observed at deflections to L/90.



**BEAM LOAD TABLES**

**TABLE 6**

**36" x 18" EXTREN DWB® - H (Hybrid)**

**Major Axis A-Basis Properties**

$E_{zz} = 5.76 \times 10^6 \text{ psi}$     $kG_{zy}A_v = 44.5 \times 10^6 \text{ psi-in}^2$     $I = 15291 \text{ in}^4$

$M_{max} = 964.0 \text{ kip-ft. @ 30' Span}$  &  $635.6 \text{ kip-ft. 40-60' Span}$

**A-Basis Allowable Distributed Loads in Pounds Per Lineal Foot**

| Span<br>in Ft. | Capacity<br>Moment | Deflection |       |       |       |       |       |       |       |
|----------------|--------------------|------------|-------|-------|-------|-------|-------|-------|-------|
|                |                    | L/180      | L/240 | L/300 | L/360 | L/420 | L/500 | L/600 | L/800 |
| 30             | 8569               | 1960       | 1764  | 1411  | 1176  | 1008  | 882   | 784   | 705   |
| 35             | 5223               | 1465       | 1319  | 1055  | 879   | 754   | 659   | 586   | 527   |
| 40             | 3178               | 1117       | 1006  | 804   | 670   | 575   | 503   | 447   | 402   |
| 45             | 2511               | 867        | 780   | 624   | 520   | 446   | 390   | 347   | 312   |
| 50             | 2034               | 683        | 615   | 492   | 410   | 351   | 307   | 273   | 246   |
| 55             | 1681               | 546        | 491   | 393   | 328   | 281   | 246   | 218   | 197   |
| 60             | 1412               | 442        | 398   | 318   | 265   | 227   | 199   | 177   | 159   |

**TABLE 7**

**36" x 18" EXTREN DWB® - H (Hybrid)**

**Major Axis B-Basis Properties**

$E_{xx} = 6.10 \times 10^6 \text{ psi}$     $kG_{xy}A = 46.2 \times 10^6 \text{ psi-in}^2$     $I = 15291 \text{ in}^4$

$M_{max} = 1139 \text{ kip ft. @ 30' Span}$  &  $916.7 \text{ kip-ft. 40-60' Span}$

**B-Basis Allowable Distributed Loads in Pounds Per Lineal Foot**

| Span<br>in Ft. | Capacity<br>Moment | Deflection |       |       |       |       |       |       |       |
|----------------|--------------------|------------|-------|-------|-------|-------|-------|-------|-------|
|                |                    | L/180      | L/240 | L/300 | L/360 | L/420 | L/500 | L/600 | L/800 |
| 30             | 10124              | 2051       | 1846  | 1477  | 1231  | 1055  | 923   | 820   | 738   |
| 35             | 6712               | 1536       | 1382  | 1106  | 921   | 790   | 691   | 614   | 553   |
| 40             | 4584               | 1173       | 1055  | 844   | 704   | 603   | 528   | 469   | 422   |
| 45             | 3622               | 911        | 820   | 656   | 547   | 468   | 410   | 364   | 328   |
| 50             | 2933               | 719        | 647   | 517   | 431   | 370   | 323   | 287   | 259   |
| 55             | 2424               | 575        | 517   | 414   | 345   | 296   | 259   | 230   | 207   |
| 60             | 2037               | 466        | 419   | 335   | 279   | 239   | 210   | 186   | 168   |

**Failure Mode:** The controlling failure mode for all beams was delamination within the compression flange, leaving the tensile flange undamaged.

**Bearing Conditions:** The values noted are valid for full width elastomeric bearing.

## BEAM LOAD TABLES

**Lateral Torsional Stability:** Flexural stiffness and strength characterizations were carried out with no lateral supports for spans to 60'. Thus, flexural strength is the controlling limit state in these conditions. Subsequent flexural tests on laterally unsupported spans @ 60' demonstrated that lateral-torsional buckling does not occur at deflections of  $L/180$ . It is, however, recommended that the beam only be loaded to  $L/360$ , allowing for a factor of safety of 2.

**Long-term Performance, Fatigue & Durability:** Fatigue testing of the girder is presently underway to assess the flexural durability of the section. Failure mode and number of cycles to failure under design loads will be determined for limited conditions. The girder has also been installed (September 2001) in the Dickey Creek bridge of Route 601 in Sugar Grove, VA.<sup>2</sup> Monitoring and field work are underway to examine the performance of the bridge and the girders under service conditions.

### OTHER SECTION PROPERTIES:

#### Shear Deformable Beams

The elastic shear properties of the section are represented by the value  $kG_{xy}A_v$ , where  $k$  is the shear correction factor (which accounts for the non-uniform shear stress distribution through the depth of the beam),  $G_{xy}$  is the shear modulus and  $A_v$  is the shear area. Because  $k$  and  $A_v$  are difficult to quantify in some cases, the full value of  $kG_{xy}A_v$  is experimentally determined for the purposes of this design manual. The A & B basis values for  $kG_{xy}A_v$  are presented in the tables preceding this section.

The **average**<sup>10</sup> shear values ( $kG_{xy}A_v$ ) have been determined as:

TABLE 8

| Beam Type        | ( $kG_{xy}A_v$ )<br>(Msi-in <sup>4</sup> ) |
|------------------|--|
| 8" DWB Hybrid    | 2.8  |
| 8" DWB All-Glass | 3.1  |
| 36" DWB Hybrid   | 46.5                                       |

<sup>10</sup> The values reported here do not include statistical variations or factors of safety.

**BEAM LOAD TABLES**

**Torsional**

Using the relationship for torsion,

$$GJ_{\text{eff}} = TL / \phi$$

the torsional section stiffness,  $GJ_{\text{eff}}$  of the hybrid beam are reported as **averages**:<sup>10</sup>

**TABLE 9**

| <b>Beam Type</b> | <b><math>GJ_{\text{eff}}</math><br/>(Msi-in<sup>4</sup>)</b> |
|------------------|--|
| 8" DWB Hybrid    | 3.1  |
| 8" DWB All-Glass | 3.4  |
| 36" DWB Hybrid   | 3170   |

where T is the applied torque, L is the span and  $\phi$  is the angle of rotation in radians.

**Minor Axis Bending Modulus of Section**

Minor axis flexural moduli were computed via laminated beam theory<sup>11, 12</sup> for bending about the yy axis. Validation of these computed values was undertaken for the 8" DWB for bending about the major axis and found to be in good agreement with the experimentally determined values discussed above. Confirmation of the 36" DWB prediction has not been completed.<sup>10</sup>

**TABLE 10**

| <b>Beam Type</b>                                | <b><math>E_{yy}</math><br/>(Msi)</b> |
|---|--------------------------------------|
| 8" DWB Hybrid ( $I_{yy}=31.8 \text{ in}^4$ )    | 5.96                                 |
| 8" DWB All-Glass ( $I_{yy}=31.8 \text{ in}^4$ ) | 3.58                                 |
| 36" DWB Hybrid ( $I_{yy}=2626 \text{ in}^4$ )   | 4.35                                 |

<sup>11</sup> E. J. Barbero, R. Lopez-Anido, and J.F. Davalos, "On the Mechanics of Thin-Wall Laminated Composite Beams," Journal of Composite Materials, v27 n8 (1993), pp. 806-829. AND,

<sup>12</sup> J. F. Devalos, H.A. Salim, P. Qiao, R. Lopez-Anido, and E.J. Barbero, "Analysis and Design of Pultruded FRP Shapes Under Bending," Composites Part B: Engineering, v27 n3-4 (1996) pp. 295-305.

### COMMENTARY:

#### Flexural Stiffness Properties and Moment Capacity Determination

Major axis bending stiffness and moment capacity was assessed at spans of 8', 14' and 20' for the 8" DWB and nominally 30', 40', 60' for the 36" DWB. A four-point bending test configuration was used to assess these performance attributes, as shown below. Measurements of load deflection and strain were taken continuously during the course of each test. Quantities recorded during the tests and their location are also noted in Figure 6. Load was applied using open loop servo hydraulic actuators. The duration of the test (from zero load to the failure load) was less than five minutes to avoid creep induced damage.

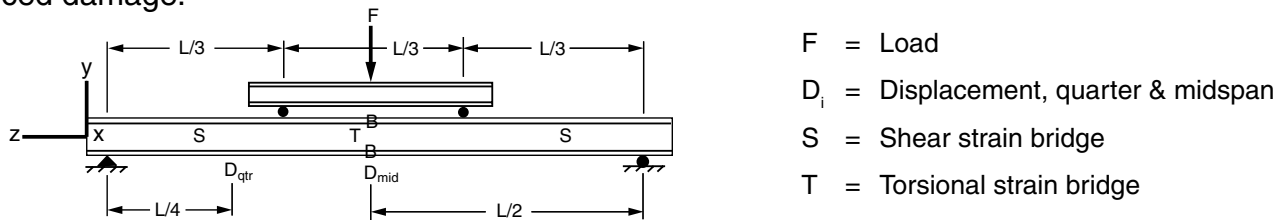

**Figure 6.** Test Set-up for the Determination of Strength and Elastic Constants

Bending strain gauges positioned within the constant moment section of the beam (see Figure 6) were used to determine the flexural modulus using the classical relationship,

$$E_{zz} = \frac{M_{xx}c}{\epsilon_{zz}I_{xx}}$$

where  $c$ , is the outer fiber distance from the neutral axis (4" for the 8" DWB and 18" for the 36" DWB). Because there are some differences in the tension and compression strains due to differences in the material response in these modes (typically only a few percent), the top and bottom strains were averaged. Again, this value only represents the strains due to bending and does not include shear effects.

Extraction of the shear contribution to deflection is accomplished by treating the section shear properties  $kG_{zy}A_v$ , as a single quantity. Again,  $k$  is the non-dimensional shear correction factor (which accounts for the non-uniform shear stress distribution through the depth of the beam),  $G_{zy}$  is the shear modulus and  $A_v$  is the shear area. Because  $k$  and  $A_v$  are difficult to quantify in some cases, the aggregate value of  $kG_{zy}A_v$  is experimentally determined for the purposes of this design guide. This was accomplished by taking the shear deformable expression for a four-point loading case,

$$\delta_{max} = \frac{7PL^3}{32EI_{xx}} + \frac{PL}{3kG_{zy}A_v}$$

and solving for  $kG_{zy}A_v$ . For each span and replicate tested, the value for  $kG_{zy}A_v$  was determined at a nominal moment. This was done for each beam tested in conjunction with its individually determined  $E_{zz}$ .

Note that in our use of the expression,  $kG_{zy}A_v$  is dependent on  $E_{zz}$  and can not be determined independently as was accomplished with the bending modulus. For this reason, the determination of A- and B-basis allowable shear properties could not be determined independently. The means to determine these allowables are discussed next.

Possessing  $E_{zz,i}$  and the  $(kG_{zy}A_v)_i$  for each beam, the distributed load,  $\omega_i$ , for each simply supported beam corresponding to a given deflection was determined using,

---

**BEAM LOAD TABLES**

---

$$\omega_i = \frac{1}{\mathbf{K} L \left\{ \frac{5L^2}{384 E_{zz,i} I_{xx}} + \frac{1}{(kG_{zy} A_v)_i} \right\}}$$

where  $\mathbf{K}$  defines the basis for the deflection criteria noted in the design tables (that is,  $\delta=L/\mathbf{K}$ ). A- and B-basis allowable distributed loads,  $\omega_a$ , were determined through the Weibull based approach discussed in this design guide. Using the A- and B-basis allowable major axis flexural modulus for the beams,  $E_{zz,a}$  the A- and B-basis allowable  $(kG_{zy} A_v)_a$ 's were determined from,

$$kG_{zy} A_v = \frac{384 \mathbf{K} L E_{zz,a} I_{xx}}{8(384 E_{zz,a} I_{xx} - 5 \mathbf{K} L^3)}$$

$\beta_{\text{lower}}$  is the value representing the lower bound of the 95% confidence interval above which 95% of the data is predicted to occur in the distribution. This is computed from,

$$\beta_{\text{lower}} = \beta \left[ \frac{2n}{\chi(2n)_{0.05}^2} \right]^{1/\alpha}$$

where  $\chi(2n)_{0.05}^2$  is the Chi-Squared of the one-sided confidence interval at 5% for n degrees of freedom (n = the number of samples or replicates). This value can be obtained from standard math tables or text on statistics.

---

**ANALYTICAL METHODOLOGY**

The preceding charts are allowable load tables for the hybrid and all-glass EXTREN DWB® when used as flexural members (beams).

These allowable loads are based upon:

1. Flexural testing conducted at ambient conditions under four-point loading
2. Laterally unsupported beams
3. Single span with simply supported ends
4. Allowable distributed loads in the plane of the web, based on strength (ultimate flexural moment capacity) and deflection determined from A- and B-basis statistics for a shear deformable beam where,

5. Because  $k$  and  $A_v$  are difficult to quantify in some cases, the full value of  $kG_{zy}A_v$  is experimentally determined for the purposes of this design guide. See the details presented in the Commentary (page 20) regarding the determination of  $kG_{zy}A_v$  and its A- and B-basis values.

$$\delta_{MAX} = \frac{5\omega L^4}{384E_{ZZ}I_{XX}} + \frac{\omega}{8kG_{zy}A_v}$$

$\omega$  = distributed load in pounds per foot of beam length

$L$  = length of the simple span

$E_{zz}$  = flexural modulus of the beam section about its major axis

$k$  = shear non-dimensional correction factor for the cross section

$G_{zy}$  = shear modulus of the beam

$A_v$  = shear area of the beam

### Determination of Allowables

Five or more replicates at each of the spans were used to compute the “allowable” design values for stiffness and strength. The allowable values are a measure of the confidence in the data and the reliability at which one desires to operate a structural system\*. Allowable values are prescribed here as opposed to arbitrary factors of safety because they represent a level of confidence in the data and a desired level of reliability prescribed for the structure. For instance, the A-basis allowable is based on a level of confidence of 95% in the data (that is, 95% of the data falls above a prescribed value) and ensures 99% reliability (only 1% of the derived values will fall below this value) in the value chosen as the design value. Likewise, the B-basis allowable prescribes a level of confidence of 95% (that is, 95% of the data falls above a prescribed value) and ensures 90% reliability (10% of the derived values will fall below this value). Both bases are presented in this design guide.

### Weibull Statistics

The basis for these calculations lies in Weibull statistics, where the cumulative probability distribution function describing the distribution of measured values is derived from,

$$F(x) = 1 - e^{-(x/\beta)^\alpha}$$

where  $\alpha$  and  $\beta$  are the two parameters used to fit the data. The value of  $\alpha$  (the shape parameter) determines the breadth of the distribution while  $\beta$  (the location parameter) defines the value most closely representing the center of the distribution. Based on the concept of reliability,  $R(x)$ , the probability of failure,  $F(x)$ , is related to the reliability by,

$$R(x) = 1 - F(x)$$

This relationship can be rearranged to form an expression for the A- and B-basis values from the following expressions,

$$A \text{ allowable} = \beta_{\text{lower}} \left[ \text{Ln} \left( \frac{1}{0.99} \right) \right]^{1/\alpha}$$

$$B \text{ allowable} = \beta_{\text{lower}} \left[ \text{Ln} \left( \frac{1}{0.90} \right) \right]^{1/\alpha}$$

\* MIL Standard: MIL-HDBK-17 (2001). Composite Materials Handbook. Available at <http://www.mil17.org>

**BEAM LOAD TABLES**

**COMMENTARY:**

**8" x 6" EXTREN DWB® Lateral Torsional Stability**

To investigate the lateral torsional buckling characteristics of the 8" x 6" EXTREN DWB®, multiple tests at varying spans were performed. These multiple tests were conducted on an unbraced, simply supported beam subjected to a single vertical load at mid-span and allowed to freely torque about the long axis of the beam and bend horizontally (see Figure 7). Simply supported ends were augmented with torsional constraints to prevent twisting.<sup>13</sup> The loading point allowed for the rotation and translation of the beam (see Figure 8). Four beams, 42' long, (two hybrid and two all-glass beams) were loaded to a deflection of L/90 at spans of 20' to 40', in 4' increments. Instrumentation was applied (including strain gauges and deflectometers) to measure the tendency of the beam to rotate and/or deflect out-of-plane as load was applied. In all cases, lateral torsional buckling was not

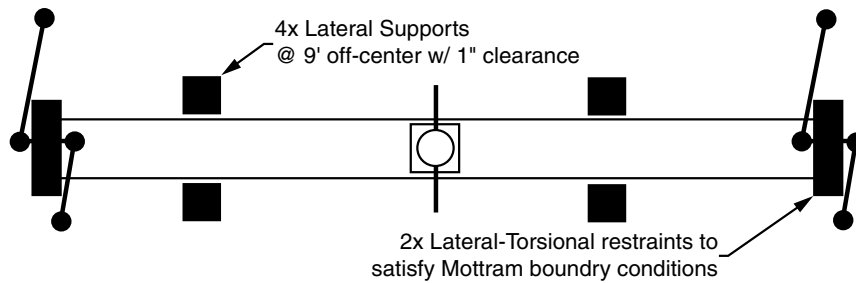

**Figure 7:** Plan view of lateral-torsional buckling test configuration.

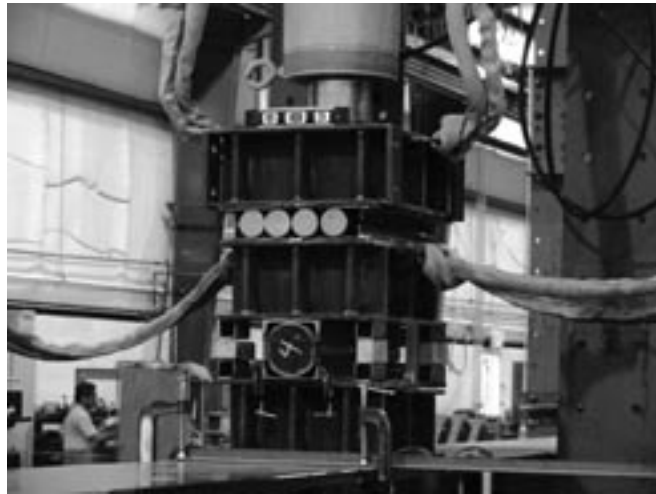

**Figure 8:** Loading point configuration to allow rotation and translation of the midspan.

<sup>13</sup> Mottram, J.T., "Lateral-Torsional Buckling of a Pultruded I-beam," *Composites*, V.23, No.2, 1992, pp. 81-92.

### 36" x 18" EXTREN DWB® Lateral Torsional Stability

A similar arrangement to that of the 8" DWB stability test was conducted for the 36" DWB. Load was applied at midspan using a conventional hydraulic ram. Load was transferred to the beam using a system of rollers that released the beam from any torsional or lateral restraints (see Figure 9). The ends of the beam rested on elastomeric bearing pads. These tests were deflection controlled, and investigated beam stability up to a deflection of  $L/180$ , or approximately 4" deflection at midspan for a test span of 60'.



**Figure 9:** Loading point configuration to allow rotation and translation of the mid-span for the 36" DWB.

Simply supported ends (on full width bearing pads) were augmented with torsional constraints to prevent twisting at the ends (preventing movement of the top flange laterally either direction). Lateral guards were used for the 36" DWB as was done for the 8" DWB (See Figure 7).

The beam was instrumented to detect lateral, vertical, and torsional movement in the beam using a system of wire pots and strain gauges. Wire pots were attached to the bottom flange to measure vertical movement, attached horizontally to the top and bottom flanges to measure twist and lateral movement, and attached to a bar projecting away from and clamped to the top flange to detect rotation. Strain gauges were placed on the bottom flange along the centerline of the beam and on the underside of each flange on each side of the beam, near the edges of the flange. Any warping of the cross section was expected to show up as a difference in the strain values.

The beam was cycled to 10 kips three times to ensure that the test set-up was both safe and working properly. The beam was then cycled to roughly 50 kips (or 4" of deflection) three times. The beam did not buckle laterally or torsionally in any of the cycles. The beam did slightly deflect laterally as it was loaded, but showed no signs of decreased load capacity.



**BEAM LOAD TABLES**

**ANALYTICAL METHODOLOGY:**

**Shear Deformable Beam Formulas**

Single span beam simply supported under a uniformly distributed load.

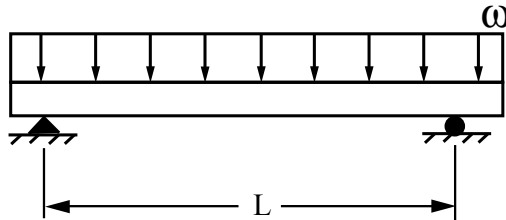
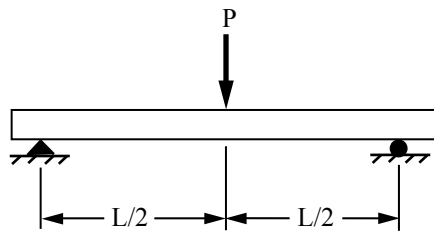

**Figure 10.**

$$\delta(z,L) = \frac{\omega}{12E_{zz}I_{xx}} \left[ \frac{z^4}{2} - Lz^3 + \frac{L^3z}{2} \right] + \frac{\omega}{2kG_{zy}A_v} [z^2 - Lz]$$

$$\delta_{Max} = \delta(z = L/2) = \frac{5\omega L^4}{384E_{zz}I_{xx}} + \frac{\omega L^2}{8kG_{zy}A_v}$$

Single span beam simply supported under a mid-span point load.



**Figure 11.**

$$\text{For } z < L/2: \delta(z,L) = \frac{Pz(24E_{zz}I_{xx} + 3kG_{zy}A_vL^2 - 4kG_{zy}A_vz^2)}{48E_{zz}I_{xx}kG_{zy}A_v}$$

$$\text{For } z \geq L/2: \delta(z,L) = \frac{P(z-L)(-6E_{zz}I_{xx} + 1/4kG_{zy}A_vL^2 - 2kG_{zy}A_vLz + kG_{zy}A_vz^2)}{12E_{zz}I_{xx}kG_{zy}A_v}$$

$$\delta_{Max} = \delta(z = L/2) = \frac{PL^3}{48E_{zz}I_{xx}} + \frac{PL}{4kGA}$$

## BEAM LOAD TABLES

Simply supported beam under four-point loading.

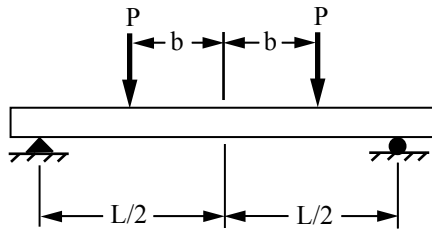

**Figure 12.**

$$\text{For } z < L/2 - b : \delta(z,L) = \frac{Pz(24E_{zz}I_{xx} + kG_{zy}A_v)(-12b^2 + 3L^2 - 4z^2)}{24E_{zz}I_{xx}kG_{zy}A_v}$$

$$\text{For } L/2 - b \leq z < L/2 + b : \delta(z,L) = \frac{P(2b - L)[-24E_{zz}I_{xx} + kG_{zy}A_v(4b^2 - 4bL + L^2 - 12Lz + 12z^2)]}{48E_{zz}I_{xx}kG_{zy}A_v}$$

$$\text{For } z \geq L/2 + b : \delta(z,L) = \frac{P(L-z)[-24E_{zz}I_{xx} + kG_{zy}A_v(12b^2 + L^2 - 8Lz + 4z^2)]}{24E_{zz}I_{xx}kG_{zy}A_v}$$

$$\delta_{\text{Max}} = \delta(z = L/2) = \frac{P(2b - L)[-24E_{zz}I_{xx} + kG_{zy}A_v(4b^2 - 4bL - 2L^2)]}{48E_{zz}I_{xx}kG_{zy}A_v}$$

Cantilevered beam under a uniform load.

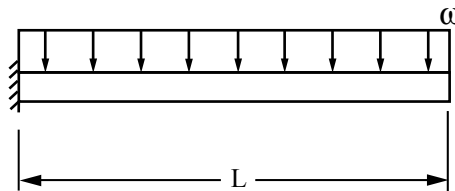

**Figure 13.**

$$\delta(z,L) = \frac{\omega}{2E_{zz}I_{xx}} \left[ \frac{z^4}{12} - \frac{Lz^3}{3} + \frac{L^2z^2}{2} \right] - \frac{\omega}{kG_{zy}A_v} \left[ Lz - \frac{z^2}{2} \right]$$

$$\delta_{\text{Max}} = \delta(z = L) = \frac{\omega L^4}{8E_{zz}I_{xx}} + \frac{\omega L^2}{2kG_{zy}A_v}$$

For further details on shear deformable beams, please see: Cowpers 1966<sup>14</sup>, Bank 1987<sup>15</sup> and Hayes 1998<sup>16</sup>.

<sup>14</sup> Cowper, G.R., "The Shear Coefficient in Timoshenko's Beam Theory," Journal of Applied Mechanics, June 1966, pp. 335-340.

<sup>15</sup> Bank, L.C., "Shear Coefficients for Thin-Walled Composite Beams," Composite Structures, Vol. 8, 1987, pp. 47-61.

<sup>16</sup> Hayes, M.D., "Characterization and Modeling of a FRP Hybrid Structural Beam and Bridge Structure for Use in the Tom's Creek Bridge Rehabilitation Project," M.S. Thesis, Department of Engineering Science & Mechanics, Virginia Tech, February 1998, electronic thesis available at <http://scholar.lib.vt.edu/theses/index.html>.

---

**BEAM LOAD TABLES**

---

**COMMENTARY:****Designing For Concentrated Loads**

As previously noted in the load tables, compression flange failure was the controlling failure mode for all spans recommended for safe use (i.e. 8'-20' for the 8" DWB and 30'-60' for the 36" DWB. Typical failure modes for both the 8" DWB and the 36" DWB are shown in Figure 14.



**Figure 14:** Typical compression flange failures for four point bend testing of the 8" DWB (top photo) and the 36" DWB (bottom photo).

## BEAM LOAD TABLES

Testing of the 8" DWB below an L/d (span to depth ratio) of 10 continued to exhibit this compression flange failure mode. However, at an L/d of 6, the 36" DWB failed at the supports, as shown in Figure 15. The magnitude of the load at which end support failure occurred is dependent on the bearing pad geometry.



**Figure 15:** Bearing failure at supports for 36" DWB tested at L/d of 6.

These data are summarized in an examination of shear capacity versus the span to depth ratio, Figure 16. The recommended bearing condition for the 36" DWB is noted as condition 3 of Figure 16 where the pad width extends only to the flange tips.

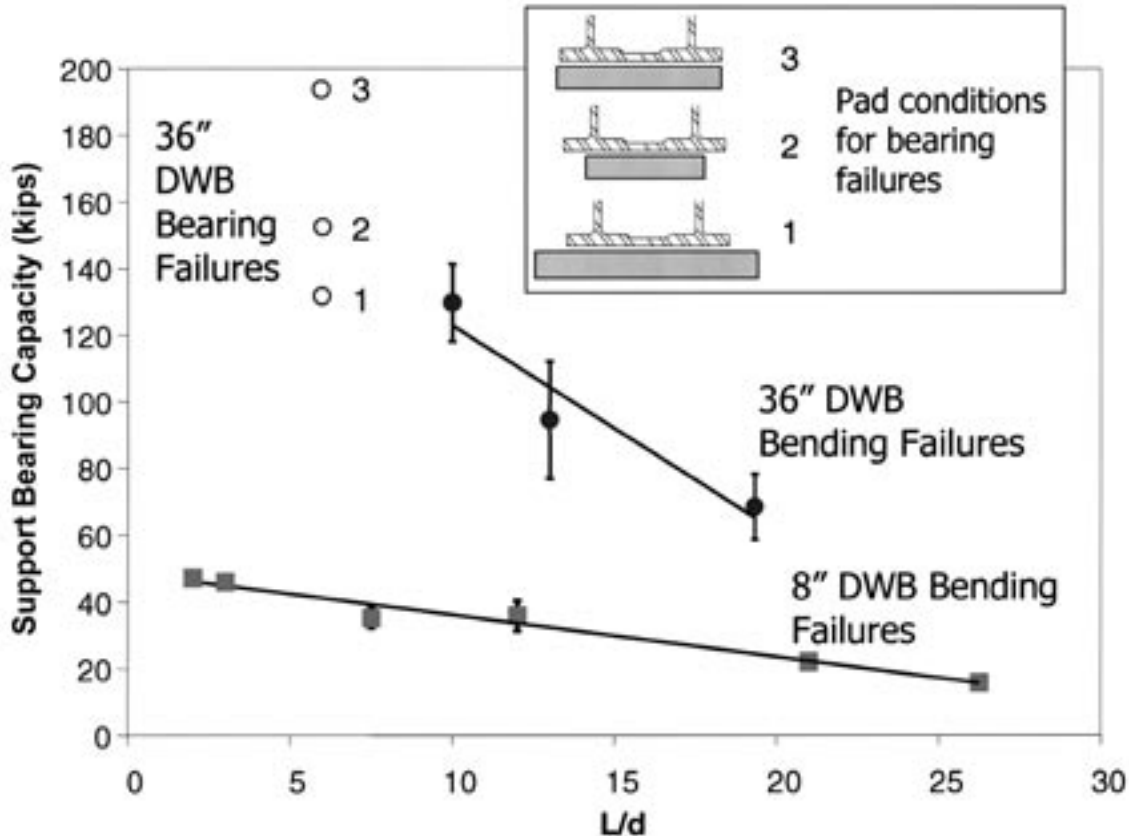

**Figure 16:** Support bearing capacity and associated failure mode as a function of the span to depth ratio for the 8" DWB and the 36" DWB.

**BEAM LOAD TABLES**

**ANALYTICAL METHODOLOGY:**

**EXAMPLE 1: Design for Concentrated Load**

**Given:** A simply supported beam of length  $L=6'$  is loaded at midspan by a concentrated load.

A-Basis Allowables:

Moment Capacity = 96.1 kip-ft

Shear Capacity = 35.6 kip

**Determine:** If the all-glass 8" DWB is to operate under A-basis allowables, what is the maximum allowed concentrated load? What is  $P_{max}$  if limited to deflection of  $L/180$ ?

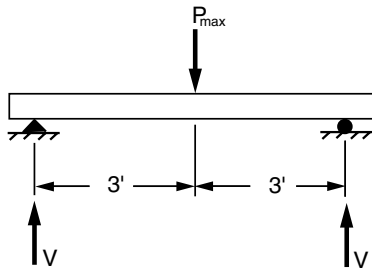

**Figure 17.**

$$P_{max} \text{ based on } M_{max}: M_{max} = \frac{PL}{4}; P_{max} = \frac{M_{max} \cdot 4}{L} = \frac{(96.1 \text{ kip-ft})(4)}{(6 \text{ ft})}$$

$$P_{max} = 64 \text{ kips}$$

$$\text{Reaction at support is } 32 \text{ kips} = V_{max}$$

$$V_{max}, V_{allowed} = 32 \text{ kips}, < 35.6 \text{ kips}$$

$$\therefore P_{max} = 64 \text{ kips} = P_{allowable}$$

limited to  $L/180$ ,  $P_{max} =$

If deflection is a constraint for design and

(not including shear deformation)

$$\frac{L}{180} = \frac{PL^3}{48EI}$$

$$P = \frac{48EI}{180 L^2}$$

$$P = \frac{(48)(4.01 \times 10^6 \text{ psi})(129 \text{ in}^4)}{180 (6 \text{ ft} \times \frac{12 \text{ in}}{\text{ft}})^2}$$

$$\therefore P_{max} = 26.6 \text{ kips} = P_{allowed}$$

### ANALYTICAL METHODOLOGY:

#### EXAMPLE 2: Design for Concentrated Load

**Given:** A simply supported 8" DWB of length  $L=13.5'$  is loaded off center @  $L/5$  by a concentrated load.

A-Basis Allowables:

Moment Capacity = 36.1 kip-ft

Shear Capacity = 13.4 kip

**Determine:** If the hybrid 8" DWB is to operate under A-basis allowables, what is the maximum allowed concentrated load if limited to deflection of  $L/180$ ?

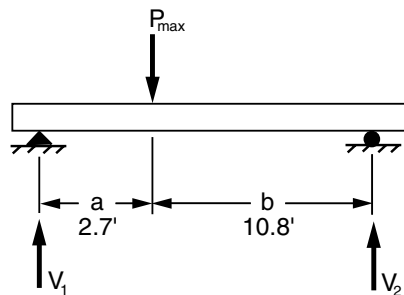

Figure 18.

$P_{max}$  from  $M_{max}$ :

$$M_{max} = \frac{ab}{L}$$

$$P_{max} = \frac{M_{max}}{ab} L = \frac{(36.1 \text{ kip-ft})(13.5 \text{ ft})}{(2.7 \text{ ft})(10.8)} = 16.7$$

$$V_{max} = V_1 = \frac{Pb}{L} = \frac{(16.7 \text{ kips})(10.8 \text{ ft})}{(13.5 \text{ ft})} = 13.4$$

$$\therefore P_{max} = P_{allowable} = 16.7 \text{ kips}$$

Note:  $V_{max} = V_{allowed}$

Checking for deflection criteria: (not including shear deformation)

$$\frac{L}{180} = \frac{Pa(L^2 - a^2)^{3/2}}{9\sqrt{3}EI L}$$

$$a = \frac{L}{5}$$

$$P_{max} = P_{allowed} = 12 \text{ kips}$$

**BEAM LOAD TABLES**

**ANALYTICAL METHODOLOGY:**

**EXAMPLE 3:** Design for Concentrated and Distributed Load

**Given:** A simply supported 8" DWB x 12' long is loaded with a distributed load of 500 lb/ft and three concentrated loads of unknown value spaced 3' apart.

B-Basis Allowables:

Moment Capacity = 51.6 kip-ft

Shear Capacity = 19.1 kip

**Determine:** If the hybrid 8" DWB is to operate under B-basis allowables, what is the maximum allowed loads P that can be applied?

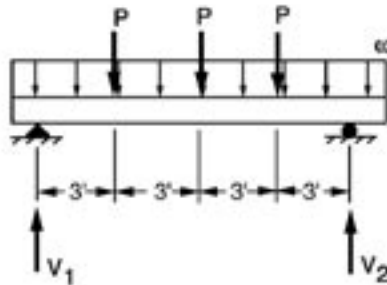

**Figure 19.**

$P_{max}$  based on moment capacity:

$$M_{max} = 9 \text{ kip-ft} + 6P$$

$$51.6 \text{ kip-ft} = 9 \text{ kip-ft} + 6P$$

$$P = \frac{(51.6 \text{ kip-ft} - 9 \text{ kip-ft})}{6} = 7.1 \text{ kips} = P_{max}$$

$P_{max}$  based on max shear capacity

The reaction at the supports are given by:

$$V_1 = V_2 = 3 \text{ kips} + 3/2 P$$

$$19.1 \text{ kip} = 3 \text{ kips} + 3/2 P$$

$$P_{max} = (19.1 \text{ kips} - 3 \text{ kips}) 2/3$$

$$P_{max} = 10.73 \text{ kips}$$

$$P_{max} = P_{allowed}$$

We must choose  $P_{max} = P_{allowed} = 7.1 \text{ kips}$  due to limits on moment capacity.

### ANALYTICAL METHODOLOGY:

#### EXAMPLE 4: Design for Concentrated Load

**Given:** A simply supported beam of length  $L=30'$  is loaded at midspan by a concentrated load.

A-Basis Allowables:

Moment Capacity = 964 kip-ft (See Table 6)

Web Buckling = 45.0 kip (See Table 11)

**Determine:** If the 36" DWB is to operate under A-basis allowables, what is the maximum allowed load? What is  $P_{max}$  if limited to deflection @  $L/360$ ?

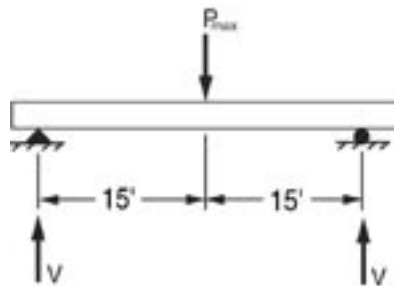

Figure 20.

$P_{max}$  based on  $M_{max}$ :

$$M_{max} = \frac{PL}{4}; P_{max} = \frac{M_{max} \cdot 4}{L} = \frac{(964 \text{ kip-ft})(4)}{(30 \text{ ft})}$$

$$P_{max} = 129 \text{ kips}$$

Reaction at support is 64.5 kips =  $V_{max}$

$$V_{max} = 64.5 \text{ kips}, > 45.0 \text{ kips}$$

$$\therefore P_{max} = (45.0 \text{ kips})(2) = 90.0 \text{ kips} = P_{allowable}$$

If deflection is a constraint for design and limited

to  $L/360$ ,  $P_{max} =$

(not including shear deformation)

$$\frac{L}{360} = \frac{PL^3}{48EI}$$

$$P = \frac{48EI}{360 L^3}$$

$$P = \frac{(48)(5.76 \times 10^6 \text{ psi})(15291 \text{ in}^4)}{360 (30 \text{ ft} \times \frac{12 \text{ in}}{\text{ft}})^3}$$

$$\therefore P_{max} = 252 \text{ kips} > P_{allowed}; \text{ therefore } P_{max} = 90.0 \text{ kips}$$



**BEAM LOAD TABLES**

**ANALYTICAL METHODOLOGY:**

**EXAMPLE 5:** Design for Concentrated and Distributed Load

**Given:** A simply supported beam of length 44' is loaded with a distributed load of 1,000 lb/ft and three concentrated loads of unknown value spaced 3' apart.

B-Basis Allowables:

Moment Capacity = 917 kip-ft (See Table 7)

Web Buckling = 50.1 kip (See Table 11)

**Determine:** If the hybrid 36" DWB is to operate under B-basis allowables, what is the maximum allowed loads P that can be applied?

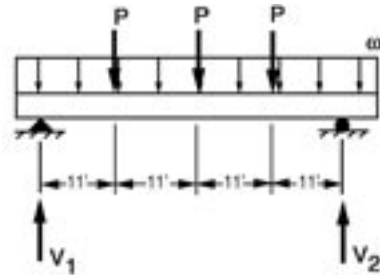

**Figure 21.**

$P_{max}$  based on moment capacity:

$$M_{max} = 242 \text{ kip-ft} + 22P$$

$$917 \text{ kip-ft} = 242 \text{ kip-ft} + 22P$$

$$P = \frac{(917 \text{ kip-ft} - 242 \text{ kip-ft})}{22} = 30.7 \text{ kips} = P_{max}$$

$P_{max}$  based on max shear capacity:

The reaction at the supports are given by:

$$V_1 = V_2 = 22 \text{ kips} + 3/2 P$$

$$50.1 \text{ kip} = 22 \text{ kips} + 3/2 P$$

$$P_{max} = (50.1 \text{ kips} - 22 \text{ kips}) \cdot 2/3$$

$$P_{max} = 18.7 \text{ kips}$$

$$P_{max} = P_{allowed}$$

We must choose  $P_{max} = P_{allowed} = 18.7 \text{ kips}$  due to limits on web buckling capacity.

**NOTE:** Also check deflection

### WEB BUCKLING

This section deals with the web buckling capacity of the double web member. Loads and/or reactions applied to the beam can fail the webs of the beam by crippling at points of high stress concentrations. The load resistance limit of the beam at these areas is referred to as the web buckling capacity of the member. Web buckling capacity for the DWB is generally critical in areas of support reactions.

**TABLE 11**

| Beam Type              | Web Buckling (kips) |         |
|------------------------|---------------------|---------|
|                        | A-Basis             | B-Basis |
| 8" DWB Hybrid or Glass | 34.1                | 47.3    |
| 36" DWB Hybrid         | 45.0                | 50.1    |

To quantify the web buckling failure mode of the 8" DWB and 36" DWB, a series of full section tests was conducted. Allowable capacities are summarized in the accompanying table.

The web buckling tests consisted of loading the top flanges of various lengths of beams through 4" x full width plates. The 4" plates simulated bearing pads in erected field conditions. It is noted that short segments were utilized in the web buckling test as opposed to full-length beam conditions seen outside of the laboratory. The tests did not incorporate vertical bearing stiffeners. It is predicted that external vertical bearing stiffeners will increase the web buckling capacity of the members. Due to the inherent design of the continual internal horizontal stiffeners, external stiffeners will only be required in extreme loading conditions. For most applications, other design considerations (web shear, flexural stress, deflection, etc.) will ultimately control the particular use of the beam.

Web buckling tests for the 36" DWB were performed on 12" lengths cut from full sections. These samples were centered in a test frame and fully supported by two (2) 9" x 18" elastomeric bearing pads. Load was applied centrally to the top flange via 1" x 4" x 1' - 6" steel plates under load controlled conditions.

It is noted that all specimens were loaded until the section would take no more additional load (i.e. additional application of load head only continued to buckle the web with no increase in load). In all samples the web buckled as shown in Figure 22.

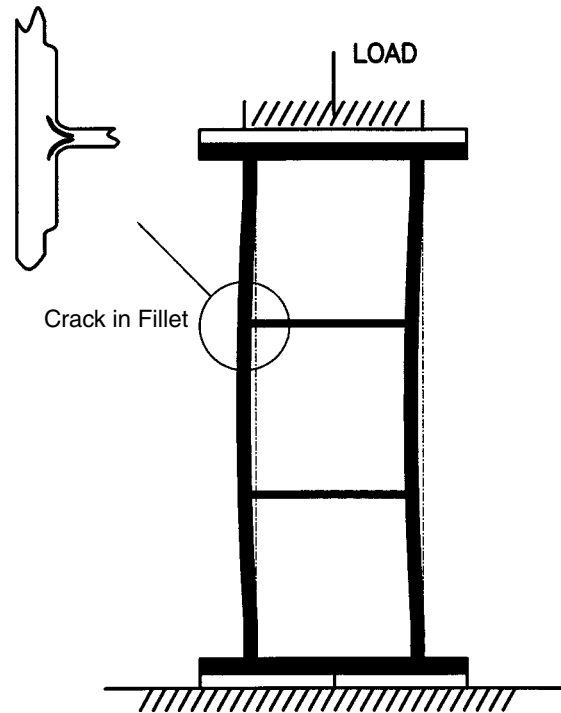

**Figure 22.** Buckling of Web

---

**CONNECTIONS**

---

**COMMENTARY:**

This section deals with web-to-web framing connections of 8" DWB members. Connections of this configuration (see Figure 23 and 24) are controlled by rotation and shear through the elements, bolt bearing of the fasteners and any related distortion, and shear of the fasteners.

Due to the performance of the EXTREN DWB® composite material and configuration, it is recommended that steel clip angles and fasteners be utilized. Testing and methodology described has been verified using stainless steel bolts and clip angles.

**Test Series**

Connection tests consisted of the following series of tests:

- Bolt Bearing Capacity

This initial battery of tests established pin bearing capacities and end/edge distances for web/pin fastening. Steel pins were passed through holes drilled in the webs and loaded perpendicular to the longitudinal axis of the pins until crushing was initiated in FRP bearing area around the pins.

- Short Beam Connection Test

Utilizing the criteria developed in the above tests, full scale bolted assemblies were fabricated and tested (see Figure 23 and 24). Short lengths of beams less than 1'-6" were incorporated to isolate shear through clip angles, shear through fasteners, and bolt bearing on fasteners/FRP.

- Long Beam Connection Test

Utilizing the criteria developed in the above tests, full scale bolted assemblies were fabricated and tested (see Figures 23 and 24). Lengths of the beams were sufficient to develop full shear and rotation through clip angles, shear and rotation through fasteners, and bolt bearing on fasteners/FRP.

Testing has demonstrated that when stainless steel fasteners and stainless steel clip angles are incorporated, the controlling element of the connection capacity is the bolt bearing into or crushing the region around the fastener.

### ANALYTICAL METHODOLOGY:

Maximum bolt bearing capacities from the series of connections may be estimated by the following equations:

$$F_{PCr} = F_U / 3.0$$

$$P = (F_{PCr}) (t_w) (d)$$

where:

$F_{PCr}$  = Critical Bearing Stress (psi)

$F_U$  = Ultimate Compressive Web Bearing Stress (psi)

$P$  = Pin Bearing Capacity (lbs)

$t_w$  = Total Web Thickness (in)

$d$  = Diameter of Fastener (in)

**Table 12**

**Allowable Bearing Capacities In Web Area of Section (in lbs.)  
8" DWB (Web Thickness = .36") and Single Pin Fastener**

| <i>Diameter of Fastener (in.)</i> | <i>Single Web (lbs.)</i> | <i>Double Web (lbs.)</i> |
|-----------------------------------|--------------------------|--------------------------|
| 1/4                               | 900                      | 1800                     |
| 3/8                               | 1350                     | 2700                     |
| 1/2                               | 1800                     | 3600                     |
| 5/8                               | 2430                     | 4860                     |
| 3/4                               | 2700                     | 5400                     |
| 7/8                               | 3150                     | 6300                     |
| 1                                 | 3600                     | 7200                     |

- Fastener Edge Distances (Web Area) - 2 diameters or 1" minimum, whichever is greater
- Fastener Pitch - 4 diameters or 3" minimum, whichever is greater

**CONNECTIONS**

**ANALYTICAL METHODOLOGY:**

**Table 13**  
**Allowable Bearing Capacities in Web Area of Section (in lbs.)**  
**36" DWB (Web Thickness = .69") and Single Pin Fastener**

| <i>Diameter of Fastener (in.)</i> | <i>Single Web (lbs.)</i> | <i>Double Web (lbs.)</i> |
|-----------------------------------|--------------------------|--------------------------|
| 1/4                               | 1725                     | 3450                     |
| 3/8                               | 2590                     | 5180                     |
| 1/2                               | 3450                     | 6900                     |
| 5/8                               | 4310                     | 8620                     |
| 3/4                               | 5175                     | 10350                    |
| 7/8                               | 6040                     | 12080                    |
| 1                                 | 6900                     | 13800                    |

- Fastener Edge Distance (Web Area) - 2 diameters or 1" minimum, whichever is greater.
- Fastener Pitch - 4 diameters or 3" minimum, whichever is greater.

**Example 1**

**Given:** 8" DWB with ultimate compressive web bearing stress of 30,000 psi\* and (l) 3/4" diameter steel pin passing through 13/16" diameter holes aligned in the webs.

**Find:** Pin bearing capacity at one web and on both webs.

$$F_{PCr} = F_U / 3.0 = 30,000 \text{ psi} / 3.0 = 10,000 \text{ psi}$$

$$\begin{aligned}
 P &= (F_{PCr}) (t_w) (d) \\
 &= (10,000 \text{ psi}) (.36") (.75") \\
 &= 2700 \text{ lb. one web}
 \end{aligned}$$

$$\text{Or } 2700 \text{ lb.} \times 2 = 5,400 \text{ lb. two webs}$$

\* Minimum coupon properties and may be affected by enviro/mechanical conditions

### ANALYTICAL METHODOLOGY:

#### Example 2

**Given:** Figure 20 – Clip angles 1/4" stainless steel ( $F_y = 48,000$  psi) and 3/4" diameter stainless steel bolts ( $F_v = 30,000$  psi). Where  $F_y$  is stress of stainless steel and  $F_v$  is bearing stress in FRP beam web.

**Find:** Capacity of connection assuming 30,000 psi\* ultimate compressive bearing stress of 8" DWB.

1. Find bearing capacity of 2 bolts in 8" DWB web area

$$\begin{aligned} F_{PCr} &= F_u / 3.0 \\ &= 30,000 \text{ psi} / 3.0 = 10,000 \text{ psi} \end{aligned}$$

$$\begin{aligned} P &= (F_{PCr})(t_w)(d) \\ &= (10,000 \text{ psi})(.36" \times 4)(.75") \\ &= 10,800 \text{ lb.} \end{aligned}$$

2. Shear through stainless steel clips

$$A_{Net}/Clip = 5.62" \times .25" - (2)(.25")(1.81") = 1.0"$$

$$F_v = .40 F_y = .40(48,000 \text{ psi}) = 19,200 \text{ psi}$$

$$P_{vSS} = F_v A = (19,200 \text{ psi})(1" \times 2 \text{ clips}) = 38,400 \text{ lb.}$$

3. Shear of stainless steel bolts in double shear

$$\begin{aligned} P_{bolts} &= F_v A_{Nom} \\ &= (30,000 \text{ psi})(.442") \times 2 \\ &= 26,520 \text{ lb.} \end{aligned}$$

4. Check pin bearing of stainless steel

$$\begin{aligned} P_{SS \text{ Pin Bear}} &= .45 F_y A \\ &= .45(48,000 \text{ psi})(2)(.25" \times .75") \\ &= 18,000 \text{ psi} \end{aligned}$$

By inspection, the connection is controlled by bearing capacity of bolts on 8" DWB or 10,800 lb.

---

**CONNECTIONS**

---

**ANALYTICAL METHODOLOGY:****Example 3**

**Given:** Figure 20 – Clip angles 1/4" stainless steel ( $F_y = 48,000$  psi) and 3/4" diameter stainless steel bolts and rods ( $F_v = 30,000$  psi).

**Find:** Capacity of connection assuming 30,000 psi\* ultimate compressive bearing stress of 8" DWB.

1. a. Find bearing capacity of 2 bolts in 8" DWB web area

$$\begin{aligned} F_{PCr} &= F_U / 3.0 \\ &= 30,000 \text{ psi} / 3.0 = 10,000 \text{ psi} \end{aligned}$$

$$\begin{aligned} P_{8"} &= (F_{PCr})(t_w)(d) \\ &= (10,000 \text{ psi})(.36" \times 4)(.75") \\ &= 10,800 \text{ lb.} \end{aligned}$$

1. b. Find bearing capacity of 2 rods in 36" DWB web area

$$\begin{aligned} P_{36"} &= (F_{PCr})(t_w)(d) \\ &= (10,000 \text{ psi})(.69" \times 2)(.75") \\ &= 10,350 \text{ lb.} \end{aligned}$$

2. Shear through stainless steel clips

$$P_{vSS} = 38,400 \text{ lb. (See Example 2)}$$

3. Shear of stainless steel bolts/rods

$$P_{bolts} = 26,520 \text{ lb. (See Example 2)}$$

4. Check pin bearing of stainless steel

$$P_{Pin Bear} = 18,000 \text{ lb. (See Example 2)}$$

By inspection, the connection is controlled by bearing capacity of bolts on 36" DWB or 10,350 lb.

**NOTES:** These details are framing and bearing connection details and are provided as suggested construction details. The designer is cautioned that particular specific site conditions may affect or require the altering of these details.

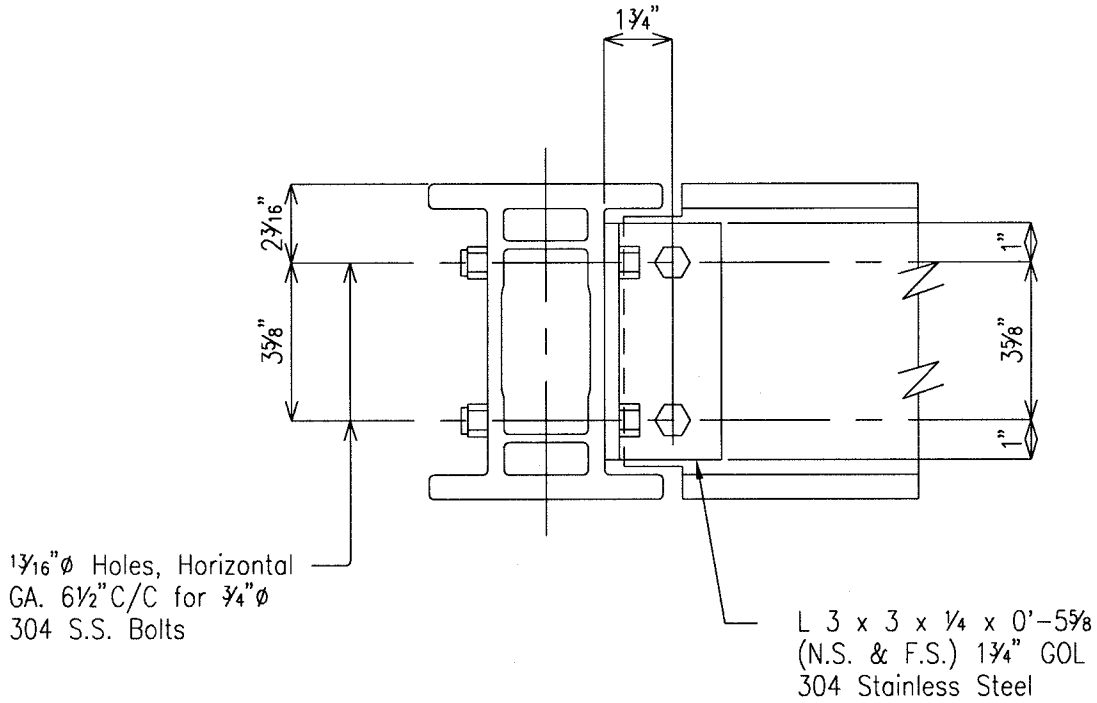

**Figure 23.** Web-to-Web Framing Connection

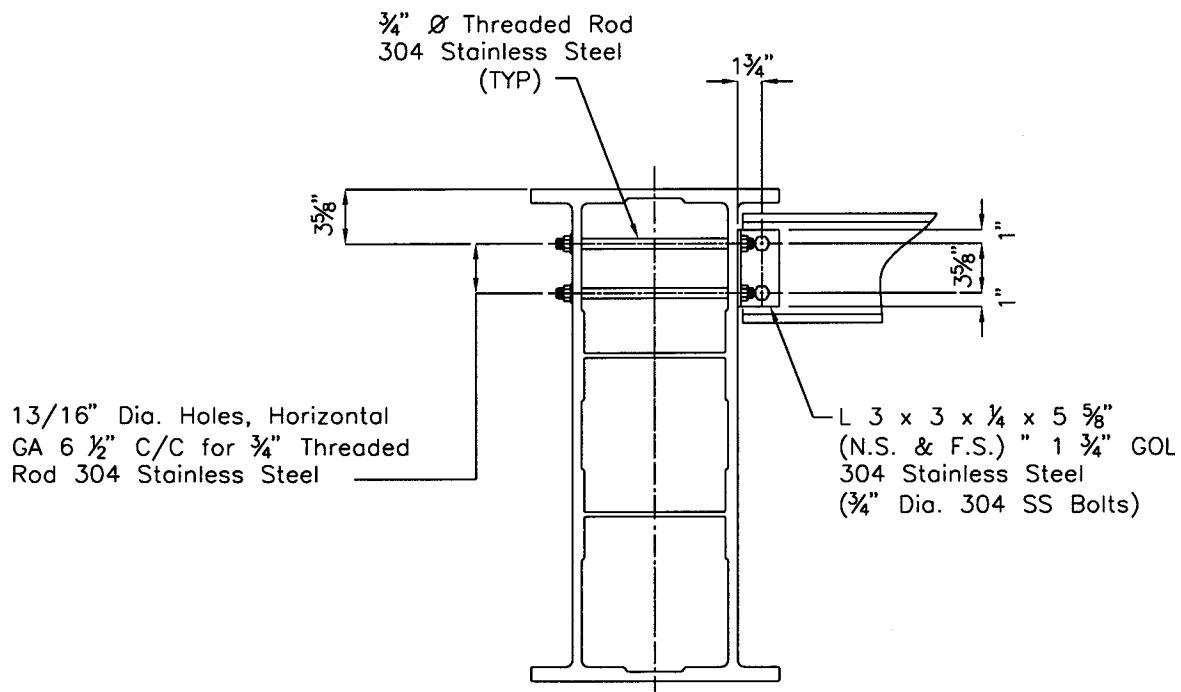

**Figure 24.** Web-to-Web Framing Connection  
8" DWB to 36" DWB



**CONNECTIONS**

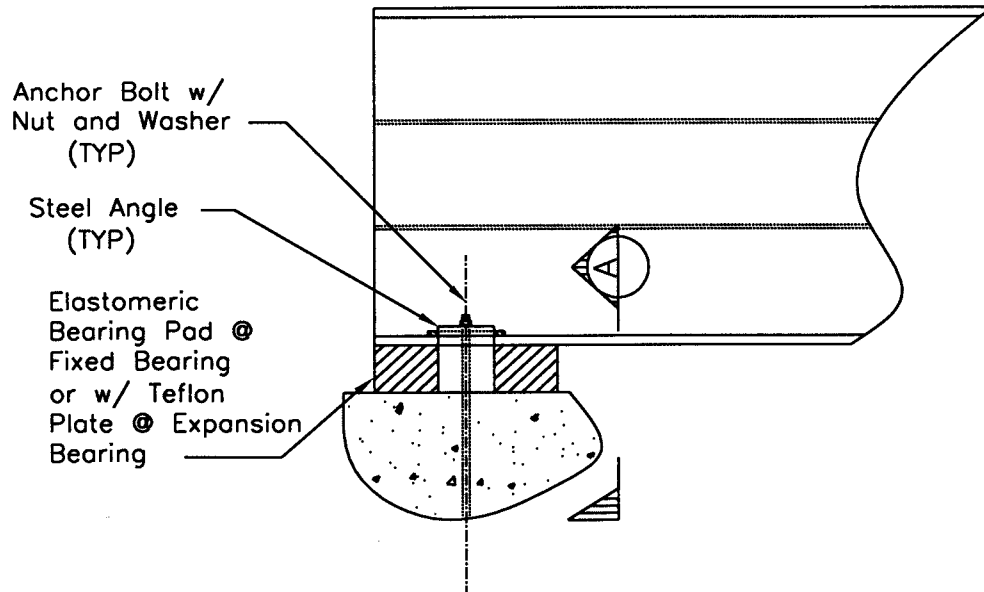

**Figure 25**

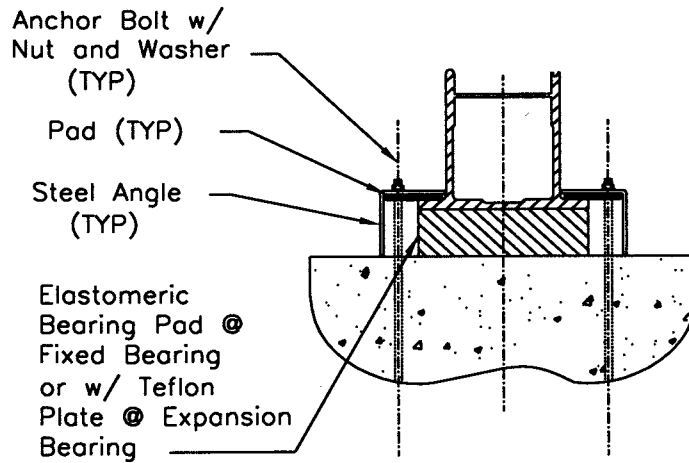

**Figure 26.** Section A—A; Bridge Bearing

## CONNECTIONS

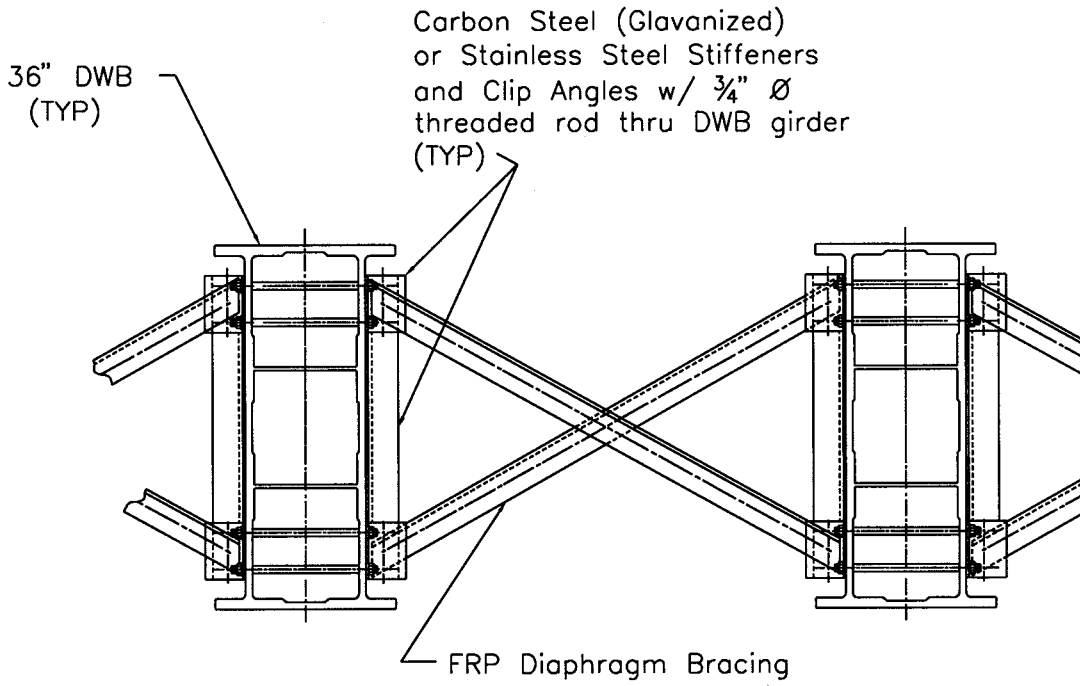

Figure 27. Bridge Diaphragm

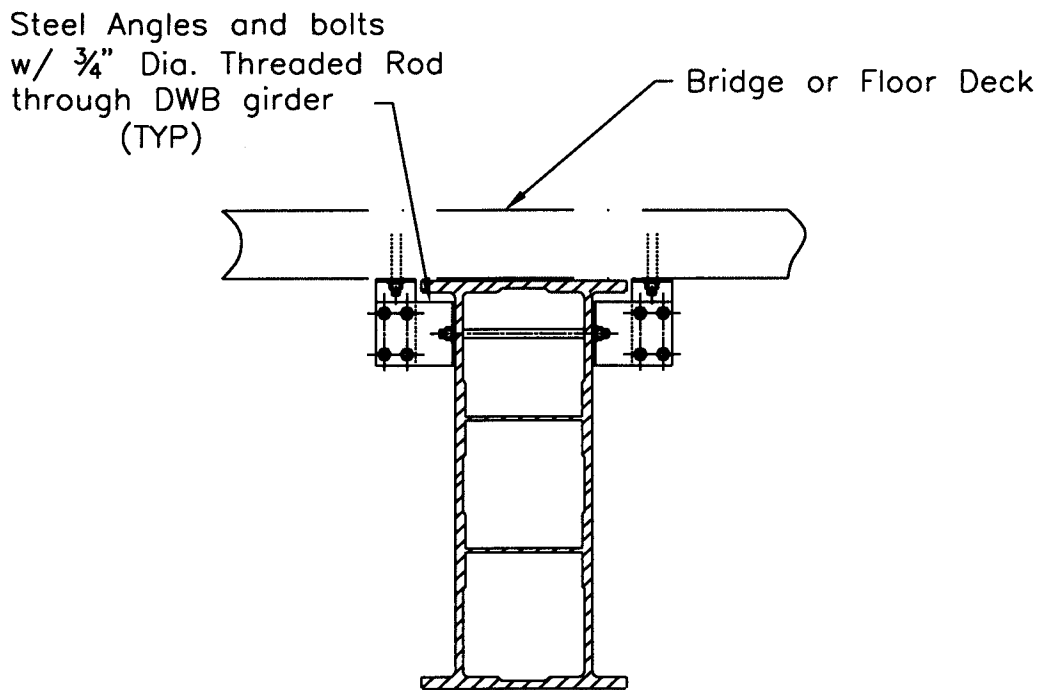
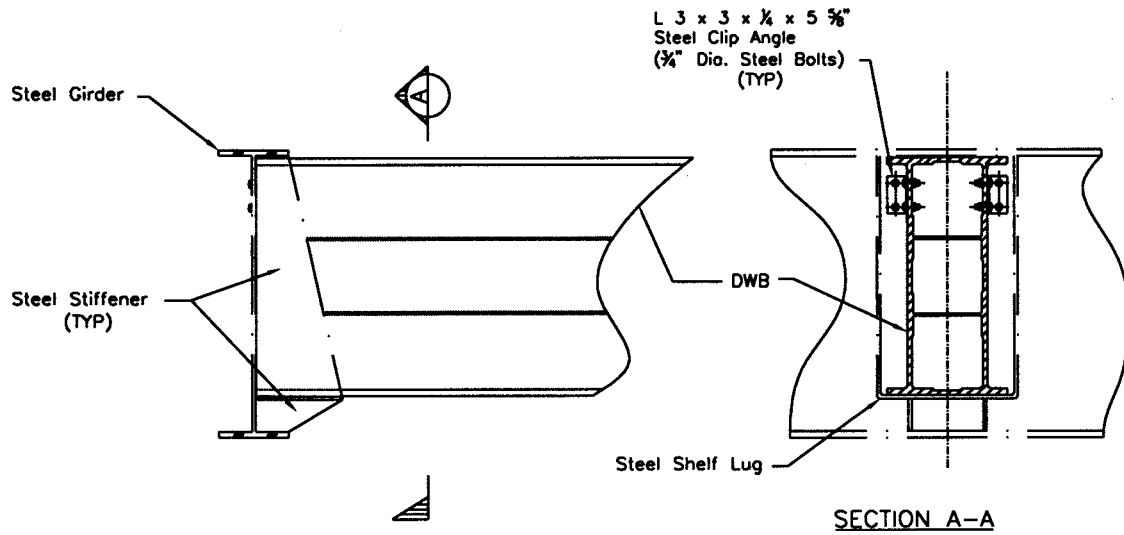

Figure 28. Deck Connection

**CONNECTIONS**



**Figure 29. Steel Shelf Lug**

### Tom's Creek Bridge

#### 8" x 6" EXTREN DWB® Demonstration Project

The Tom's Creek Bridge is a small-scale demonstration project involving the use of 8" x 6" EXTREN DWB® hybrid beams as the main load carrying members in a short-span bridge. The Tom's Creek Bridge is located in Blacksburg, VA and was built during the Summer of 1997.

The project is intended to serve two purposes. First, by calculating bridge design parameters such as the dynamic load allowance, transverse wheel load distribution and deflections under service loading, the Tom's Creek Bridge will aid in modifying current American Association of State Highway and Transportation Officials (AASHTO) bridge design standards for use with FRP composite materials. Second, by evaluating the FRP girders after being exposed to service conditions, the project will begin to answer questions about the long-term performance of these advanced composite material beams when used in bridge design.

This project involved replacing the superstructure in the Tom's Creek Bridge, a rural short-span (18 feet) medium volume vehicular traffic bridge with corroded steel girders and a timber deck. Twenty-four (24) 8" DWB hybrid beams and a glulam timber deck with asphalt surface were used to rehabilitate the bridge. In order to verify the composite girder design and to address construction issues prior to the rehabilitation, a full-scale mock-up of the bridge was built and tested in the laboratory. This set-up utilized the actual composite beams, glulam timber deck panels, and geometry to be implemented in the rehabilitation. (Figure 30)

After the rehabilitation was completed, the bridge was field tested under a known truck load. Five load tests nominally, at six-month intervals, were conducted. Using midspan strain and deflection data gathered from the FRP composite girders during these field tests, the above mentioned bridge design parameters were obtained. The Tom's Creek Bridge was determined to have a dynamic load allowance of 0.90, a transverse wheel load distribution factor of 0.101 and a maximum live load deflection of  $L/490$ . Also, no significant long-term change in these parameters for the bridge were noted over the 3 year duration.

Two 8" DWB bridge girders were removed from the Tom's Creek Bridge after 15 months of service. These FRP composite girders were tested at the Structures and Materials Research Laboratory at Virginia Tech for residual stiffness and ultimate strength and compared to pre-service values for the same beams. This analysis indicates that after 15 months of service, the FRP composite girders had not significantly changed in stiffness or ultimate moment capacity.

For complete details about this project see the theses of Michael David Hayes and William Douglas Neely at <http://etd.vt.edu/>.



**Figure 30.** Full scale mock-up of Tom's Creek Bridge.



**Figure 31.** Installation of the Tom's Creek Bridge.

---

**APPENDIX**

---

**Route 601 Dicky Creek Bridge****36" x 18" EXTREN DWB® Demonstration Project**

The Virginia Route 601 Bridge, spanning 39 feet over Dickey Creek in Sugar Grove, VA, is the first use of Strongwell's 36" x 18" EXTREN DWB® hybrid beams as the main load carrying members in a low volume vehicular traffic bridge. The bridge was designed with the aid of the American Association of State Highway and Transportation Officials' (AASHTO) Standard Specification for Highway Bridges for an AASHTO HS20-44 and alternate military loading with a targeted deflection limit of  $L/800$ . To meet the deflection target, eight beams were required and spaced transversely at 3.5 feet. A glulam timber deck was used with an asphalt overlay and the guard rail was a crash tested glulam system. The photos below show the Route 601 bridge.

The experimental research related to the Route 601 Bridge consisted of two phases. The first phase, completed in July of 2001, consisted of testing eleven 36" DWB beams (eight of these beams were used in the bridge) to determine their stiffness properties ( $E$  and  $kG_{xy} A_v$ ) to insure that these properties were above the values assumed in the preliminary design. One of these eleven girders was then tested to failure to determine the failure mode and flexural strength of the 36" DWB. The test of the beam to failure revealed a safety factor of over 7 against the AASHTO service load.

The second phase began in October of 2001 after construction of the Route 601 Bridge was completed and consisted of field testing the bridge to determine girder distribution factors, dynamic load allowance, and service load deflections for the structure. To evaluate the in-service behavior of the bridge, mid-span deflections and strains were continuously recorded during live load tests with a vehicle slightly above the legal load limit for the bridge. The wheel load distribution factors in the AASHTO Standard Specification for Highway Bridges for glulam timber decks on steel stringers were found to apply to this bridge. A dynamic load allowance was determined to be 0.36 (slightly larger than that specified in AASHTO), and the maximum deflection of the bridge was  $L/1100$ . This improvement in deflection performance is attributed to partial composite action of the deck-to-girder connections, bearing restraint at the supports, and contribution of guardrail stiffness. It was also found that the absence of a midspan diaphragm had a minimal effect on the wheel load distribution factor.

For complete details about this project see the theses of Christopher J. Waldron and Edgar Salom Restrepo at <http://etd.vt.edu/>.



**Figure 32.** Route 601 Bridge Superstructure







For pricing call: GEF Incorporated, Winfield WV (304) 755-1600

GEF Incorporated